

**SECTION A - A**

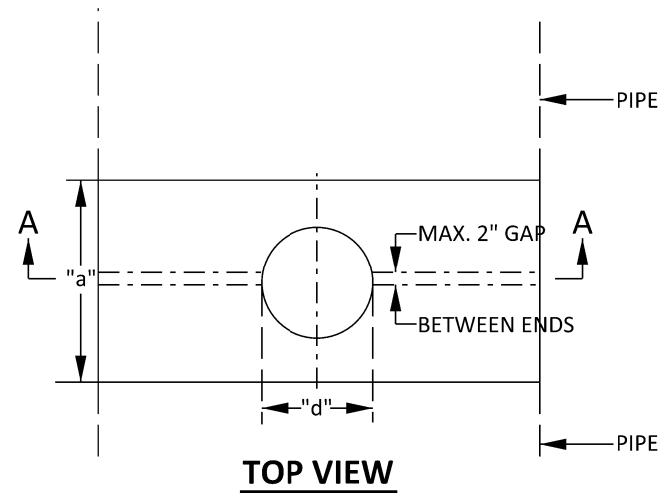

**TOP VIEW**

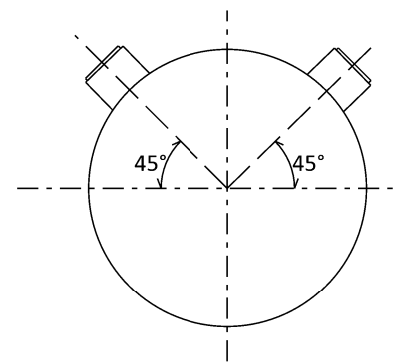



18" - 27" PIPE WILL HAVE 2 HAND HOLES PER THE ABOVE DETAIL. ALL OTHER DIMENSIONS & DETAILS REMAIN THE SAME

**NOTES:**

1. I.D. OF THE BUTT STRAP EQUALS O.D. OF PIPE

| NOMINAL PIPE DIA | "a" | "b" | "c"   | "d"   | "e" (MIN) |
|------------------|-----|-----|-------|-------|-----------|
| 4"               | 6"  | 4"  | 4.026 | 4.500 | 1/8"      |
| 6"               | 6"  | 4"  | 4.026 | 4.500 | 1/8"      |
| 8"               | 6"  | 4"  | 4.026 | 4.500 | 1/8"      |
| 12"              | 8"  | 4"  | 4.026 | 4.500 | 1/8"      |
| 14"              | 8"  | 4"  | 4.026 | 4.500 | 1/8"      |
| 16"              | 8"  | 6"  | 6.065 | 6.625 | 1/8"      |
| 18"              | 8"  | 6"  | 6.065 | 6.625 | 1/8"      |
| 20"              | 10" | 6"  | 6.065 | 6.625 | 3/16"     |
| 21"              | 10" | 6"  | 6.065 | 6.625 | 3/16"     |
| 24"              | 10" | 6"  | 6.065 | 6.625 | 3/16"     |
| 27"              | 10" | 6"  | 6.065 | 6.625 | 3/16"     |
| 30"              | 10" | NO  | HAND  | HOLE  | 3/16"     |
| 33"              | 10" | NO  | HAND  | HOLE  | 1/4"      |
| 36"              | 10" | NO  | HAND  | HOLE  | 1/4"      |
| 39"              | 10" | NO  | HAND  | HOLE  | 1/4"      |
| 42"              | 10" | NO  | HAND  | HOLE  | 5/16"     |
| 45"              | 10" | NO  | HAND  | HOLE  | 5/16"     |
| 48"              | 10" | NO  | HAND  | HOLE  | 5/16"     |

| REVISIONS                                |         |         |                                   |              | APPROVALS |  |         | EASTERN MUNICIPAL WATER DISTRICT STANDARD DRAWING |   |
|--|---------|---------|-----------------------------------|--------------|-----------|--|---------|---|---|
| NO.                                      | DATE    | INITIAL | DESCRIPTION                       | APP'D        | DATE      | DESIGN   | INITIAL | DATE  | <br>EASTERN MUNICIPAL WATER DISTRICT |
|  |         |         |                                   |              |           | CONSTRUCTION   |         |   |   |
|  |         |         |                                   |              |           | INSPECTION   |         |   |   |
|  |         |         |                                   |              |           | OPERATIONS   |         |   |   |
|  |         |         |                                   |              |           | SUBMITTED  |         |   |   |
| 2  | 9/11/20 | GS      | UPDATED TITLE BLOCK, LOGO, & FONT | AGA          | 9/11/20   |  |         |   |   |
| 1  | 1/98    | TS      | REDRAWN W/CADD ON MYLAR           | VJB          | 1/27/98   |  |         |   |   |
| REFERENCES:                              |         |         |                                   | SCALE: NONE  |           | <br>APPROVED _____ DATE _____ |         |   |   |
| FILE I.D.: \kauai\eng\std dwgs\B-304.dgn |         |         |                                   | DRAWN BY: GS |           |  |         |   |   |

**B-304**

