

STAIR ELEVATION

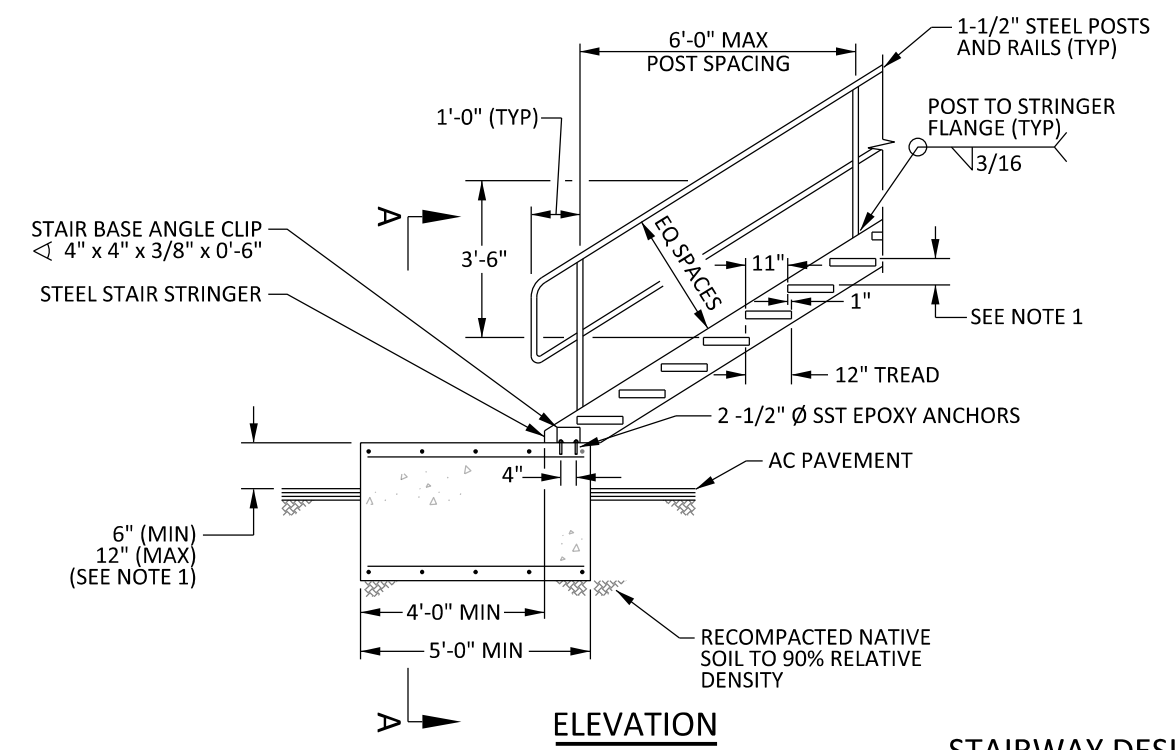

ELEVATION

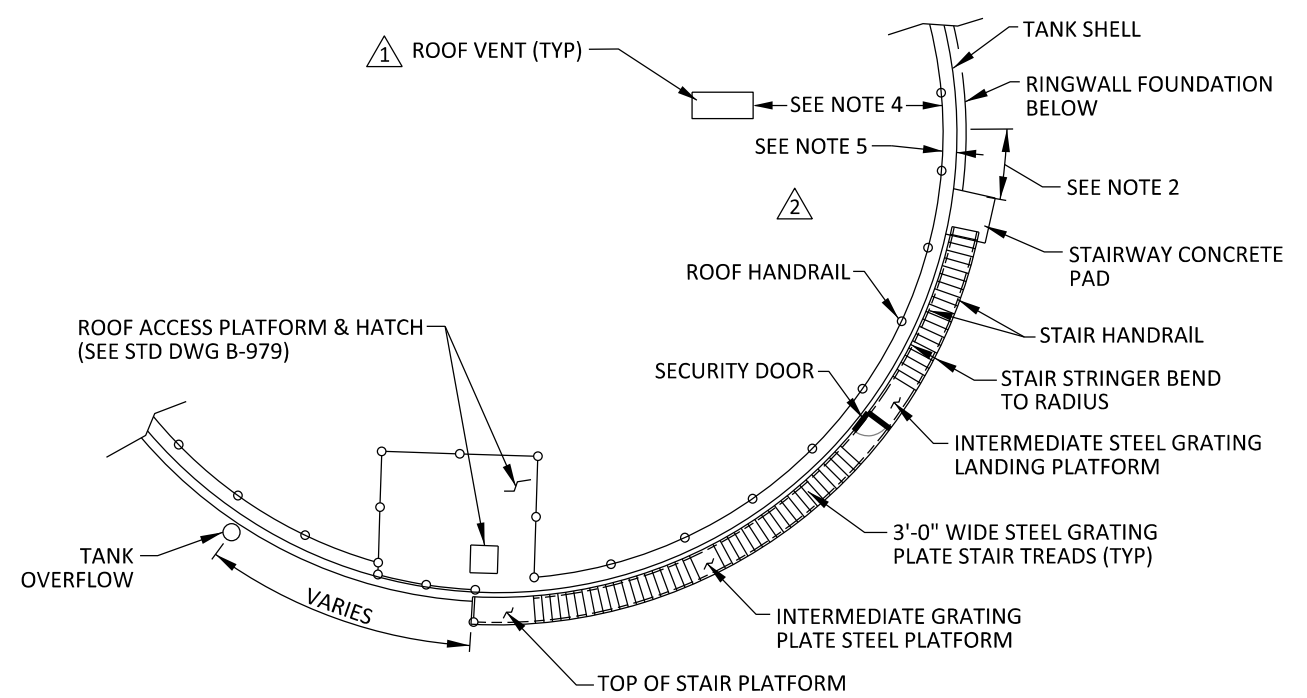

EXTERIOR STAIR PLAN

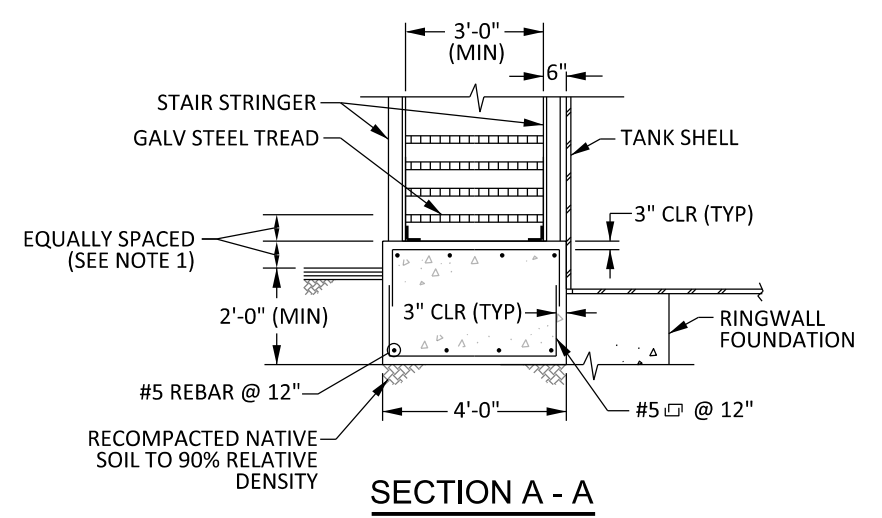

SECTION A - A

STAIRWAY HANDRAIL AND CONCRETE PAD

STAIRWAY DESIGN LOADS

- STAIR TREAD = 100 PSF
- STAIR LANDING = 125 PSF
- HANDRAILING = ASCE 7 (CURRENT EDITION) AND CALOSHA

SCHEDULE OF MATERIALS

HANDRAIL	STEEL, PAINTED TO MATCH TANK EXTERIOR
GRATING (STAIR TREADS AND PLATFORM)	STEEL, HOT-DIP GALVANIZED
SECURITY DOOR	STEEL, PAINTED TO MATCH TANK EXTERIOR
STAIR STRINGERS	STEEL, PAINTED TO MATCH TANK EXTERIOR

NOTES:

1. STAIR TREAD TO HAVE RISE AND RUN PER OSHA REQUIREMENTS. HEIGHT OF CONCRETE LANDING PAD ABOVE GROUND TO BE EQUAL TO STAIR RISE.
2. BOTTOM OF STAIRWAY SHALL BE AT LEAST 4'-0" CLEAR OF OBSTRUCTIONS FOR APPROPRIATE ACCESS.
3. KEEP TOP AND SIDES OF HANDRAIL CLEAR. ONLY HANDRAIL AT LANDINGS AND PLATFORM TO HAVE KICK PLATE.
4. PROVIDE SUFFICIENT CLEARANCE BETWEEN THE HANDRAIL AND ROOF VENTS.
5. PERIMETER HANDRAIL SHALL BE INSET 6 INCHES FROM TOP OF KNUCKLE. WHERE NO KNUCKLE EXIST. PERIMETER HANDRAIL SHALL BE INSET 6 INCHES FROM TANK SHELL.

REVISIONS						APPROVALS			 EASTERN MUNICIPAL WATER DISTRICT		EASTERN MUNICIPAL WATER DISTRICT STANDARD DRAWING	
NO.	DATE	INITIAL	DESCRIPTION	APP'D	DATE	DESIGN	INITIAL	DATE			TYPICAL STEEL TANK CIRCUMFERENTIAL STAIRWAY (VARIES PER TANK AND HIEGHT)	
						CONSTRUCTION	<i>MJ</i>	8/29/12	RECOMMENDED <i>Joe Mouawad</i> 8/15/12 <small>DIRECTOR OF ENGINEERING DATE</small>		APPROVED <i>Charlie J. Bachmann</i> 8/29/12 <small>ASSISTANT GENERAL MANAGER DATE</small>	
						INSPECTION	<i>CD</i>	8/29/12				B-977
△	4/16/24	GS	REVISED ROOF HANDRAIL, NOTES, AND DETAILS	<i>CRC</i>	4/16/24	OPERATIONS	<i>KG</i>	8/28/12	RECOMMENDED <i>Joe Mouawad</i> 8/15/12 <small>DIRECTOR OF ENGINEERING DATE</small>		APPROVED <i>Charlie J. Bachmann</i> 8/29/12 <small>ASSISTANT GENERAL MANAGER DATE</small>	
△	12/17/12	SL	REVISED ROOF HANDRAIL AND ROOF VENT	<i>GK</i>	12/18/12	SUBMITTED	<i>GK</i>	8/14/12				B-977
REFERENCES:				SCALE: NONE		RECOMMENDED <i>Joe Mouawad</i> 8/15/12 <small>DIRECTOR OF ENGINEERING DATE</small>		APPROVED <i>Charlie J. Bachmann</i> 8/29/12 <small>ASSISTANT GENERAL MANAGER DATE</small>		B-977		
FILE I.D.: J:\Master CAD Files - Restricted\B-977.dgn				DRAWN BY: SL								

